

Type A:
for horizontal assembly

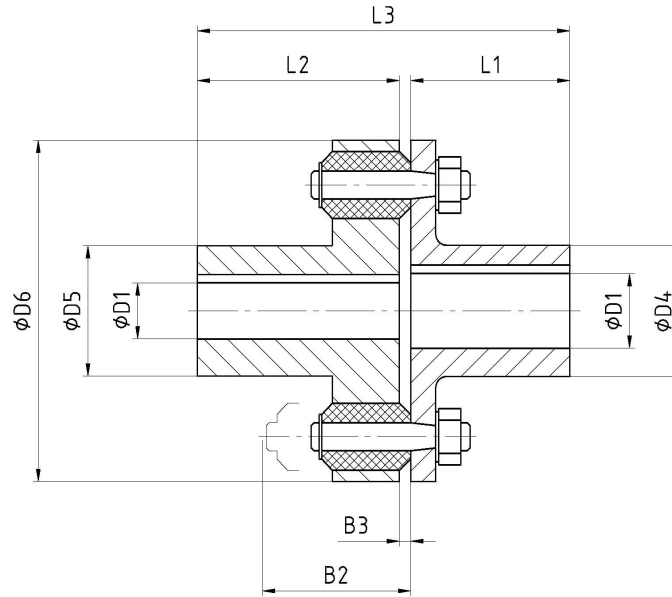

nominal size	torque ¹⁾ [Nm]		D1 ²⁾		D4 ³⁾	D5	D6	L1	L2	L3	B2	B3 (±25%)	moment of inertia ⁴⁾ J [kgm ²]	weight ⁴⁾ m [kg]	permissible speed ⁵⁾ n _{max} [rpm]	cushions and pins	
	T _{KN}	T _{KNmax}	min	max												nominal size	number
4	40	60	18	32	45	42	82	50	40	93	41	3	0,001	1,1	5000	6	4
6,3	63	95	18	38	52	50	90	60	50	113	41	3	0,001	1,4	4600	6	6
10	100	150	18	42	58	56	98	60	50	113	41	3	0,002	1,7	4300	6	8
16	160	240	18	45	62	60	112	60	60	123	57	3	0,003	2,5	4050	8	8
25	250	375	20	48	70	65	118	80	60	145	59	5	0,004	3,3	3850	8	10
40	400	600	22	55	78	70	135	80	80	165	72	5	0,007	4,7	3650	10	10
63	630	950	22	65	92	85	150	110	80	195	72	5	0,012	6,7	3500	10	12
100	1000	1500	28	75	95	95	182	110	90	205	92	5	0,032	10,5	3350	14	8
160	1600	2400	32	85	120	115	205	110	110	225	92	5	0,057	15,6	3200	14	10
250	2500	3750	42	95	135	130	230	140	110	255	107	5	0,098	22,1	3100	16	12
400	4000	6000	45	110	145	145	275	140	110	255	127	5	0,185	31,9	3000	22	10
630	6300	9500	90	120	165	165	320	170	170	348	130	8	0,398	48	2700	22	12
1000	10000	15000	90	130	175	175	380	170	170	348	150	8	0,631	64	2300	30	10
1600	16000	24000	90	160	210	210	440	210	210	430	165	10	1,65	110	2000	30	12
2500	25000	37500	110	180	240	240	510	210	210	430	210	10	3,14	164	1800	42	10
4000	40000	60000	140	200	270	270	630	250	250	510	290	10	7,75	296	1600	65	6
6300	63000	95000	140	220	300	300	660	300	300	610	336	10	11,35	370	1300	65	8
10000	100000	150000	160	220	335	320	770	350	300	660	336	10	21,16	525	1200	65	10

1) torsion angle at T_{KN} φ=3°±1°

2) finished boring to ISO-fit H7, keyway to DIN 6885 P1 fit JS9, other diameter on request

3) true for D1 max, in case of smaller boring a reduction is possible

4) true for D1 max, in consideration of buffers and pins

5) higher speed on request

dimensions in mm

Material of standard type

Hub buffer side, hub pin side:

Pin:

Buffer:

C35 or GS52

C35, 34CrMo4, 34Cr4

PUR (Elastopal)65±5 Shore A

PUR (Elastollan)80±2 Shore A

In special case of operation or by customer request it is possible to apply other material.

Order example:

EBK A 40 – 35H7P1 – 40H7P1 - dy

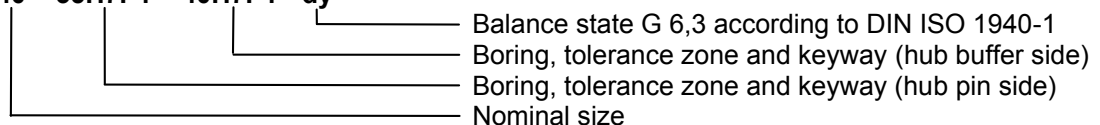

All data subject to change without notice