

Non- driven wheel

spherical roller bearing model series 223

Dimensions

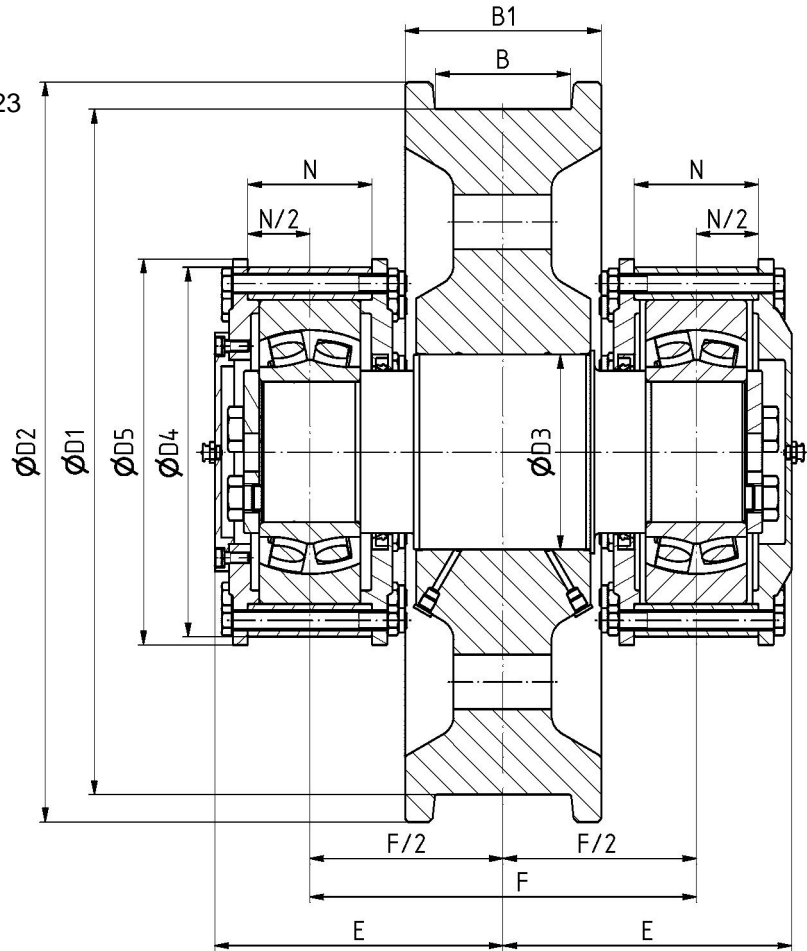
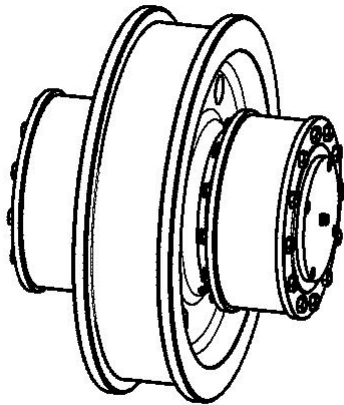

D1	D2	D3	D4	D5	B1	E	F	N	B		Bearing DIN 635	weight [kg]
									min	max		
315	350	120	240	250	110	191	255	82	55	65	223 18	140
400	440	130	265	275	140	216	295	92	65	90	223 20	220
500	540	140	300	315	140	242	325	104	65	90	223 22	320
630	680	180	340	355	160	265	355	114	75	110	223 26	515
710	760	190	360	375	210	300	415	124	95	160	223 28	720
800	850	200	380	395	210	308	425	132	95	160	223 30	895

Example of identification:

Non- driven wheel acc. DIN 15090 – BHKE 315 x 65

 All dimensions in mm
 Weight is approximate declaration

• Material: axis/ wheel 42CrMo4V

- Track gauge B
- Nominal diameter D1
- B – wide wheel
- H – with flanges or G – without flanges
- K – without rim
- E – without oil-pressure interference fit assembly or
- D – with oil-pressure interference fit assembly

Subject to change without notice

 Straße der Freiheit 1
 D - 07318 Saalfeld / Saale

Saalfelder Hebezeugbau GmbH

Unternehmensbereich Komponenten

Phone: +49 3671/441 341

Fax: +49 3671/441 343