

## Dimensions

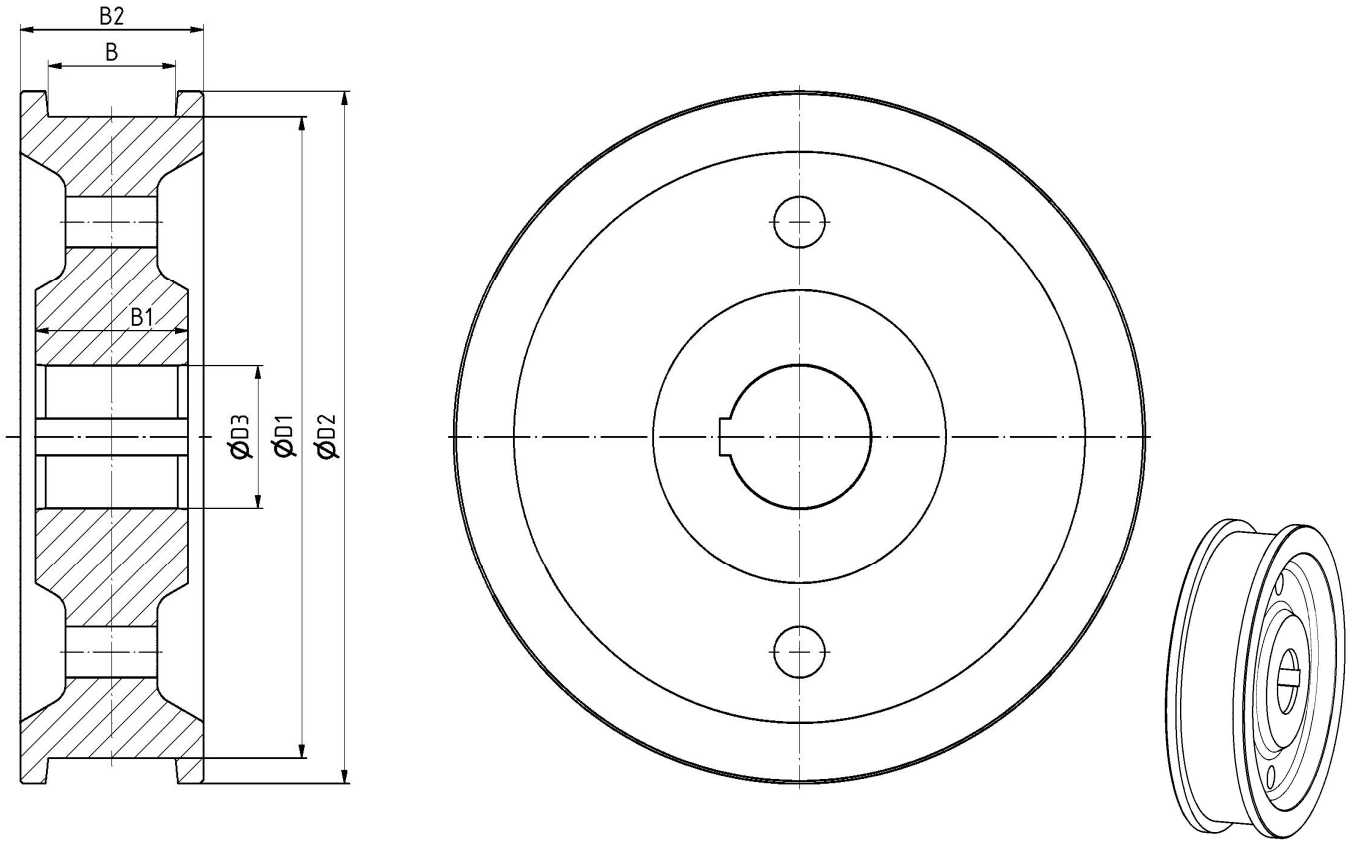

D1	D2	D3	B1	B2	B		weight [kg]
					min	max	
320	350	90	125	130	40	90	75
400	440	105	140	160	50	120	140
500	540	115	140	160	50	120	200
630	680	140	150	180	60	130	360
710	760	150	160	180	60	130	520
800	850	160	175	200	80	150	630

### Example of identification:

Wheel according to TGL 34968 - 320 x 75 – P1

**Material: 42CrMo4V**

All dimensions in mm  
Weight is approximate declaration

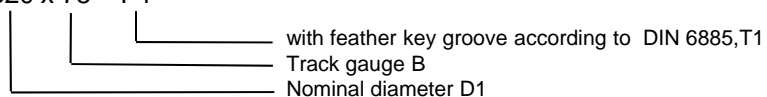

Subject to change without notice

Straße der Freiheit 1  
D - 07318 Saalfeld / Saale

**Saalfelder Hebezeugbau GmbH**  
**Unternehmensbereich Komponenten**

Phone: +49 3671/441 341

Fax: +49 3671/441 343