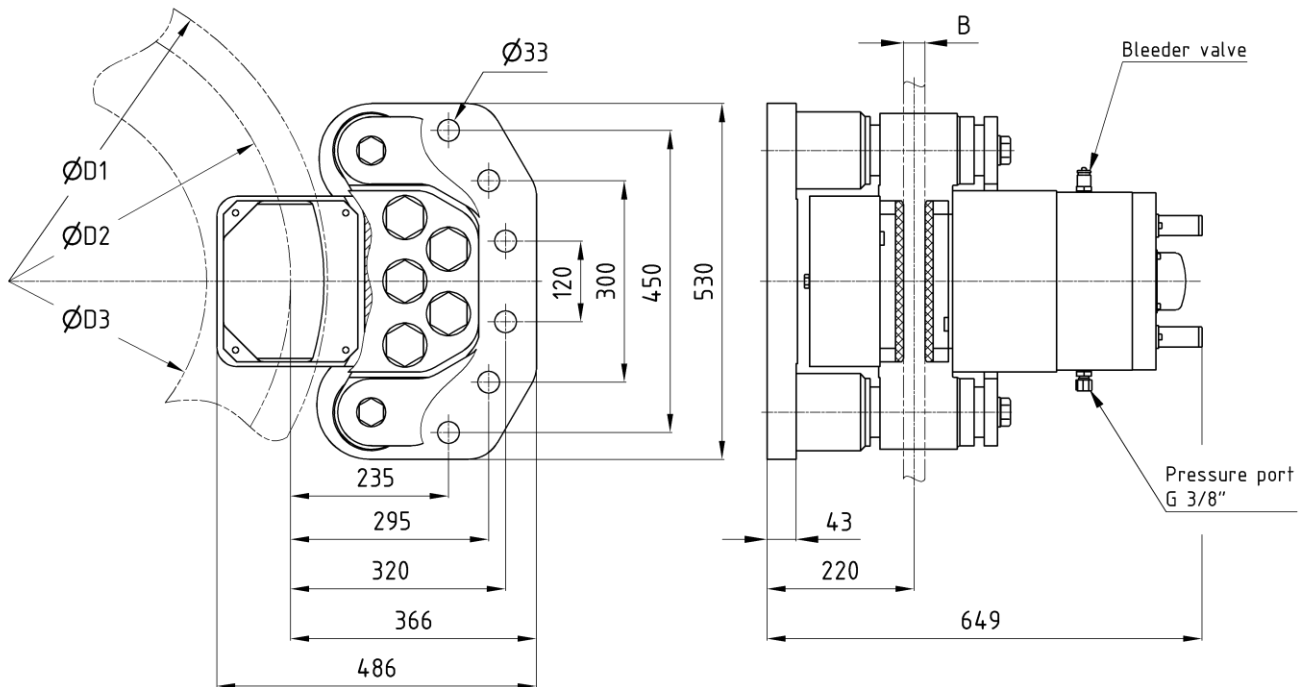

Disc brake DBF 320 S

dimensions and technical data

 edition 06/2022 | EN
 page 1 / 1

Order example: DBF 320.x S - D1 x B

dimensions in [mm]

Technical data

Braking torque [kNm]					
$M_{Br} = F_A \cdot (D2 / 1000) \cdot \mu$					
Friction coefficient $\mu = 0,4$					
Clamp force F_A [kN] ¹⁾					
Air gap	1 mm	2 mm	3 mm	Pressure [bar]	M_A ²⁾ [Nm]
DBF 320.1 S	200	170	140	145	8.8 - 2300
DBF 320.2 S	230	200	170	160	8.8 - 2500
DBF 320.3 S	260	230	200	180	8.8 - 2700
DBF 320.4 S	290	260	230	200	8.8 - 2900
DBF 320.5 S	320	290	260	215	10.9 - 3100
DBF 320.6 S	-	320	290	235	10.9 - 3300
Brake disc					
Brake disc diameter D1				min 800 mm	
Friction diameter D2				D1 - 110 mm	
Hub diameter D3				D1 - 360 mm	
Brake disc thickness B				min 25 mm	

Operational data	
Release time ³⁾	1 - 2,5 s
Theoretical close time ⁴⁾	ca. 0,2 s
Pad surface	315 cm ²
Maximum pressure	250 bar
Oil volume	0,28 l
Oil volume at working stroke	0,045 l
Hydraulic connection	G 3/8" / pipe Ø12 x 1,5
Operating temperature	-20°C bis +60°C
Screw size / strength	M32 - 8.8 / 10.9
Weight without mounting bracket	425 kg

- Axial clearance of ± 15 mm can be compensated.
- Available with mounting bracket and assembled hydraulic power unit, filled and bled as „plug and play“- version.
- Inductive proximity switch for monitoring brake open position as standard.
- optional: Inductive proximity switch for monitoring Air gap and / or brake closed position.

1) The clamp force can vary between 5%.

2) Screw tightening torque is specified for ungreased thread. The usage of screws and nuts without surface treatment is recommended.

3) The brake release time depends strongly on the used hydraulic power unit.

4) The theoretical close time can only be achieved with the correct size of the hydraulic pipe.