

Brake drum according to TGL 38558

edition 06/2022 | EN
page 1 / 1

web at the front side

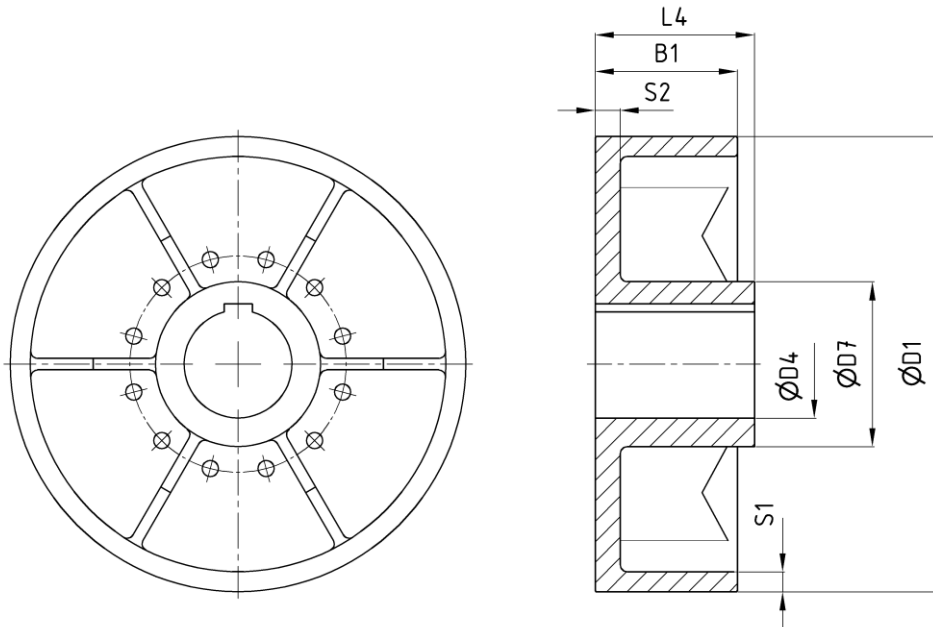

Order example: brake drum NG - D1 - D4H7P1 - dy ²⁾

dimensions in [mm]

Technical data

Nominal size NG	M _B [Nm]		n _{max} ³⁾ [1/min]	D1	B1	D4 ⁴⁾		D7	S1	S2	J _{rot} ⁵⁾ [kgm ²]	m ⁵⁾ [kg]			
	T _{kN}	T _{kmax}				min	max								
16	160	240	3000	160	50	18	45	65	7,5	11	0,013	3,4			
			3000	200	65								10,0	11	0,034
			3000	250	80										
40	400	600	3000	200	65	22	55	78	10,0	11	0,042	6,7			
			3000	250	80								10,0	11	0,097
			3000	320	100										
100	1000	1500	3000	250	80	28	75	108	10,0	18	0,12	16,0			
			3000	320	100								12,5	18	0,32
			2400	400	125										
250	2500	3750	3000	320	100	42	95	145	12,5	20	0,41	27,0			
			2400	400	125								17,5	22	1,05
			1900	500	160										
630	6300	9500	1900	500	160	90	120	165	22,5	20	3,10	94			
			1500	630	200								25,0	20	8,00
1000	10000	15000	1350	710	225	90	130	175	27,5	25	12,70	225			
1600	16000	24000	1350	710	225	90	160	210	27,5	25	14,40	259			

- 1) Execution of the brake drum from Ø500 with ribs
- 2) material: GE 200 (Standard), S355J2G3 on request
- 3) Use at higher speeds on request
- 4) finish bore size according to DIN EN ISO 286-1 H7, keyway according to DIN 6885-1 JS9, balancing quality G 6,3 according to DIN ISO 1940-1 other diameters and fits on request
- 5) data for D4 max