

Type D:
 for horizontal or
 vertical assembly

Flexible pin coupling

with brake drum according to DIN 15431

edition 06/2022 | EN
 page 1 / 1

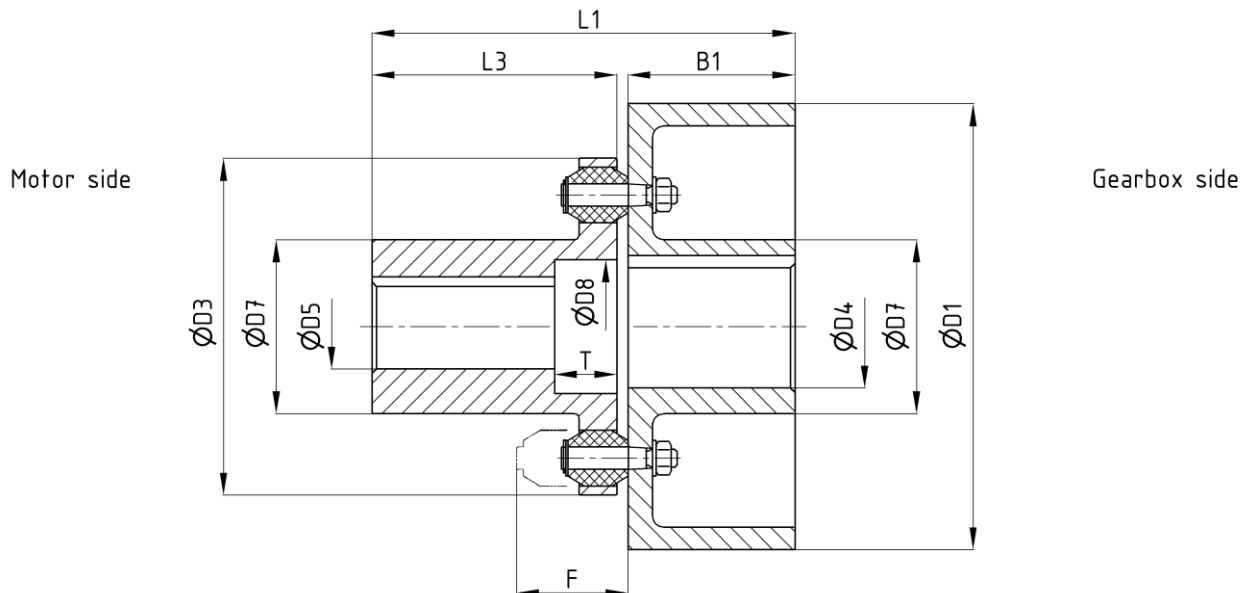

Order example: EBK D NG - D1 - D4H7P1 - D5H7P1 - D8 x T - dy

dimensions in [mm]

Technical data

Nominal size NG	M _B ¹⁾ [Nm]		n _{max} ²⁾ [1/min]	D1	B1	D3	D4 ³⁾		D5 ³⁾	D7	D8	T	L1	L3	F	J _{rot} [kgm ²]	m [kg]	M _A [Nm]					
	T _{kN}	T _{kmax}					min	max											max	max			
16	160	240	3000	160	60	135	18	45	32	65	50	22	143	80	54	0,017	7,1	5,1					
			3000	200	75		22	38					78			64	28		210	110	67	0,038	9,3
			3000	250	95		28	60					108			92	35		263	140	87	0,087	13
40	400	600	3000	200	75	170	22	55	38	78	64	28	190	110	67	0,055	15	16					
			3000	250	95		28	60					108			92	35		263	140	87	0,110	19
			3000	315	118		28	60					108			92	35		295	140	87	0,304	28
100	1000	1500	3000	250	95	215	28	75	60	108	92	35	240	140	87	0,17	28	43					
			3000	315	118		28	75					108			92	35		263	140	87	0,36	36
			2400	400	150		28	75					108			92	35		295	140	87	1,00	51
250	2500	3750	3000	315	118	290	42	95	80	145	119	40	293	170	102	0,58	59	43					
			2400	400	150		42	95					145			119	40		325	170	102	1,22	72
			1900	500	190		42	95					145			119	40		365	170	102	2,78	96
630	6300	9500	1900	500	190	330	90	120	90	165	146	45	408	210	122	3,73	148	106					
			1500	630	236		90	120					165			146	45		454	210	122	8,59	200
1000	10000	15000	1350	710	265	390	90	130	100	175	159	45	483	210	142	14,00	275	370					
1600	16000	24000	1350	710	265	450	90	160	110	210	178	45	485	210	155	17,20	355	370					

- 1) torsion angle at T_{kN} φ = 3° ± 1°
- 2) Use at higher speeds on request
- 3) Finish boring according to DIN EN ISO 286-1 H7, keyway according to DIN 6885-1 JS9, balancing quality G 6,3 according to DIN ISO 1940-1
Other diameters and fits on request
- 4) Standard: Buffer made from PUR 85 Shore A, nature, operating temperatur from -40° C up to +80° C / other materials on request